

11.3Gb/s Full-band Tunable Super-X2 Transceiver

TL8000 Series

Features:

- Electrical interface compatible with XFP MSA Rev 4.5
- Up to 11.3Gb/s data rate
- Zero Chirp $\pm 800\text{ps/nm}$ dispersion tolerance
- Negative Chirp Transmitter option available
- Up to +4.5dBm EOL optical power output
- C-Band Tunability covering 96 channels, other options available.
- L-Band version also available.
- 50GHz channel spacing.
- Extended reach enabled via integrated EDC functionality
- Excellent performance in low OSNR environments
- +12dBm Rx damage threshold
- -5°C to $+75^{\circ}\text{C}$ operating case temperature range
- Typically < 3W power consumption
- Hot Pluggable
- Duplex LC connector
- XFI electrical interface
- Comprehensive diagnostics over 2 wire interface

Compliance:

- Telcordia GR-253-CORE
- ITU-T G.691
- IEEE 802.3ae
- CDRH & IEC Laser Safety
- IEC/EN60950 Product Safety
- RoHS 5/6 compliant 

Applications:

- Long Haul and Regional Metro
- SONET OC-192 / SDH STM-64
- 10G Ethernet
- 10G Fibre channel

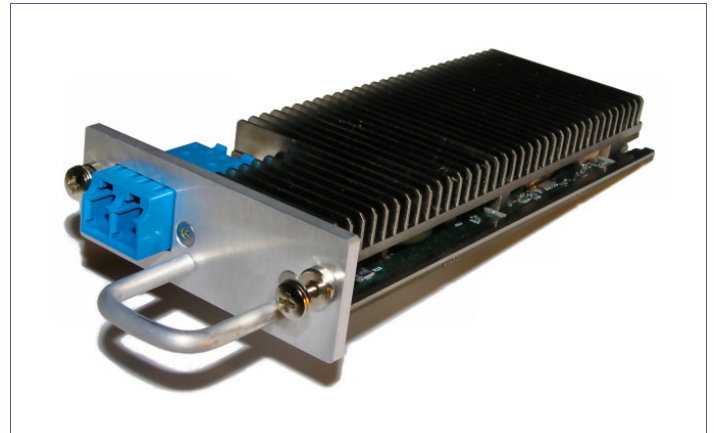

The Oclaro TL8000 optical transceiver is a high-performance, cost-effective full band tunable transceiver module for serial optical data communication applications at 10Gb/s. Similar to XFP-E, the TL8000 is designed to provide 10G SONET/SDH and 10G Ethernet (both with or without FEC) for $\pm 800\text{ps/nm}$ dispersion for compensated applications or $+1600\text{ps/nm}$ dispersion links for uncompensated applications.

The modules are designed for single mode fibre applications over the entire C-Band and are transmission protocol transparent. The “hot pluggable” feature of the module reduces manufacturing cost, inventory costs and allows optical port upgrades at the customer premises. Built-in remote diagnostics monitoring allows user access to static and dynamic data as well as module condition.

The TL8000 uses the Oclaro DS-DBR tunable laser technology and the InP Mach Zehnder modulator. This design provides for maximum eye opening, minimized jitter generation, and excellent back reflection performance. The transmitter is fully IEC60825-1 and CDRH Class 1 laser eye safety compliant. The receiver employed is an APD with excellent sensitivity performance optimized for noise loaded links and very high damage threshold.

Absolute Maximum Ratings

Parameter	Symbol	Min	Max	Units	Notes
Storage Temperature	T _{STG}	-40	85	°C	
Storage Relative Humidity	RH _{STG}	5	95	%	
+5.0V Supply voltage	V _{CC5}	-0.3	6.0	V	
+3.3V Supply voltage	V _{CC3}	-0.3	3.6	V	
+1.8V Supply voltage	V _{CC2}	-0.3	2.1	V	
-5.2V Supply voltage	V _{EE5}	-6.0	0.3	V	
RF AC voltage differential	Tx+, Tx-	-0.5	2.0	V _{PP}	
RF DC voltage	Tx+, Tx-	0	V _{CC2}	V _{PP}	
Low speed digital signal inputs	V _{LSD}	-0.3	3.6	V	
Optical Damage Threshold	P _{damage}	+12		dBm	

Operating Conditions

Parameter	Symbol	Min	Typical	Max	Units	Notes
Data Rate	DR	9.95		11.32	Gb/s	9.95328Gb/s & 10.709225Gb/s 10.3125Gb/s & 10.51875Gb/s & 11.0957Gb/s & 11.3176Gb/s
+5V Supply voltage	V _{CC5}	4.75	5.0	5.25	V	
+5V Supply current	I _{CC5}		TBC	1000	mA	
+3.3V Supply voltage	V _{CC3}	3.15	3.3	3.47	V	
+3.3V Supply current	I _{CC3}		TBC	2000	mA	
+1.8V Supply voltage	V _{CC2}	1.71	1.8	1.89	V	
+1.8V Supply current	I _{CC2}		TBC	2000	mA	
-5.2V Supply voltage	V _{EE5}	-4.94	-5.2	-5.46	V	
-5.2V Supply current	I _{EE5}		TBC	1000	mA	
Power Dissipation	P		TBC	7.0	W	
Relative Humidity	RH _{OP}	5		85	%	
Case Temperature	T _{CASE}	-5		75	°C	

Note:

- [1] Typical figures for supply current and power dissipation represent start-of-life 75°C.
Max figures for supply currents and power dissipation are worst case, end-of-life, over temperature.
Currents are quiescent values and exclude inrush.
- [2] Maximum currents from each supply rail not all present simultaneously.

Transmitter operating specifications – optical performance

Performance data presented here is valid for all operating conditions described on Page 2

Parameter	Symbol	Value			Units	Notes
		Min	Typical	Max		
Operating Wavelength Range		1527.6		1565.5	nm	
Operating Frequency Range		191.15		196.05	THz	
Frequency Spacing			50		GHz	
Total Number of Channels				96		
Signal Coding			NRZ			
Data Rate		9.95		11.32	Gb/s	
Locked Frequency accuracy		-2.5		+2.5	GHz	EOL
Optical Transmit Power (EOL)	P_o	+3.0		+6.0	dBm	Pre-Chirped
Power Output Variation		-1.0		+1.0	dB	
Power Output (Tx_DIS)			-45	-38	dBm	
SMSR		40	45		dB	
Linewidth			1	5	MHz	Lorentzian
SBS Threshold		+18			dBm	
Extinction Ratio	ER_{zC}	12	13		dB	Unchirped
Extinction Ratio	ER_{NC}	10	11		dB	Pre-Chirped
Optical Rise / Fall Time	T_R / T_F			35	ps	20 – 80%
Crossing Point		45	50	55	%	
Output Optical Eye	Compliant with Telcordia GR-253, ITU-T G.691/G.959.1 and IEEE802.3ae					
Mask Margin		10			%	
Jitter Generation	TJ_{rms}	Compliant to GR-253 Issue 4 and ITU-T G.825/G.8251			UI	RMS
Jitter Generation	TJ_{p-p}				UI	Peak-to-Peak

Receiver operating specifications – optical performance

Performance data presented here is valid for all operating conditions described on Page 2

Parameter	Symbol	Value		Units	Notes
		Min	Max		
Receiver Sensitivity (dBm)	@ OTU2 (10.7Gb/s) and (11.3Gb/s)	-26.0	-6.0	dBm	
OSNR penalty (per 0.1nm) with data rates	@OTU2 (10.7Gb/s) @OTU2 (11.3Gb/s)		0 0.5	dB dB	
Receiver Overload			-6.0	dBm	
Receiver Damage Threshold		+12		dBm	
OSNR variation over temperature -5C to 75 C	OSNR 14 to 17 dB Dispersion = 0 ps/nm		0.5	dB	
BER spec	At 0ps/nm and 14dB OSNR for -24 to -6 dBm Rx power		3.3E-5	dB	
OSNR variation vs. Fiber Dispersion at BER < 3.3E-5	-800 to +800 ps/nm		1.5	dB	
Dispersion penalty in high OSNR metro environment	+1600ps/nm		2.0	dB	1
Reflectance			-27	dB	
Loss of Signal Assert (off to on)	P _A	-30	-28	dBm	selectable
Loss of Signal Deassert (on to off)	P _D		-26	dBm	
Hysteresis	P _A - P _D	0.5	3.0	dB	

Operating Specification – electrical

Performance data presented here is valid for all operating conditions described on Page 2

Parameter	Symbol	Value			Units	Notes
		Min	Typical	Max		
CML Input (differential)	V _{TxDiff}	150		900	mV _{PP}	100 ohm differential
CML Output (differential)	V _{RxDiff}	360	600	770	mV _{PP}	100 ohm differential
Rise/Fall Time	T _R / T _F	24			ps	20% - 80%
Loss of Signal Output Voltage High	V _{OH}	2		V _{CC3} +0.3	V	Note 1
Output Voltage Low	V _{OL}	0		0.8	V	
Tx_Disable High	V _{DH}	2		V _{CC3} +0.3	V	
Tx_Disable Low	V _{DL}	0		0.8	V	

NOTE: The TL8000 module requires a 1/64 rate reference clock to be supplied by the host card. Please refer to XFP MSA document, Section 3.10 "Reference Clock Specifications", for further details.

[1] Loss of Signal is implemented in a manner which does not comply with the XFP MSA specification. Please see Reference Doc [4]

Operating Specifications – Jitter

Performance data presented here is valid for all operating conditions described on Page 2

Parameter	Symbol	Value			Units	Notes
		min	typical	max		
Jitter Tolerance	J _{TOL}	Compliant to GR-253 Issue 4 and ITU-T G.825/G.8251			UI	
Jitter Transfer	J _{TRAN}	Compliant to GR-253 Issue 4 and ITU-T G.825/G.8251			UI	
Jitter generation	J _{GEN}	Compliant to GR-253 Issue 4 and ITU-T G.825/G.8251			UI	

Electrical Pin Out

The electrical connection interface of the host board and module is shown below in Figure 1 and Figure 2, respectively.

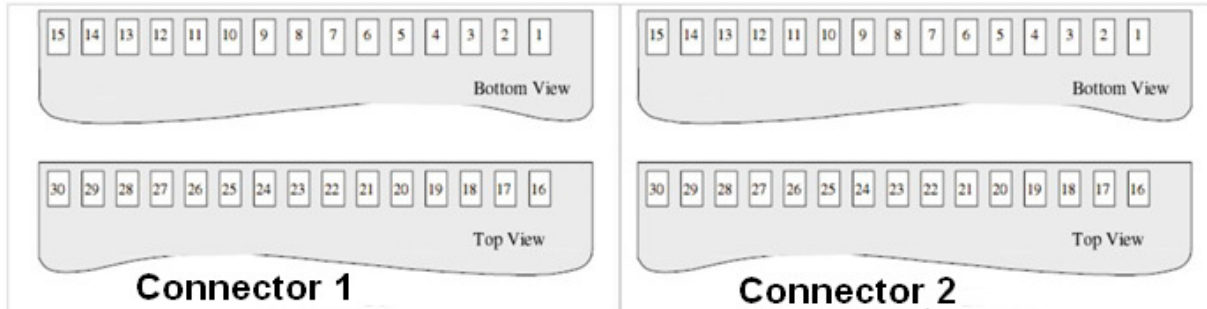
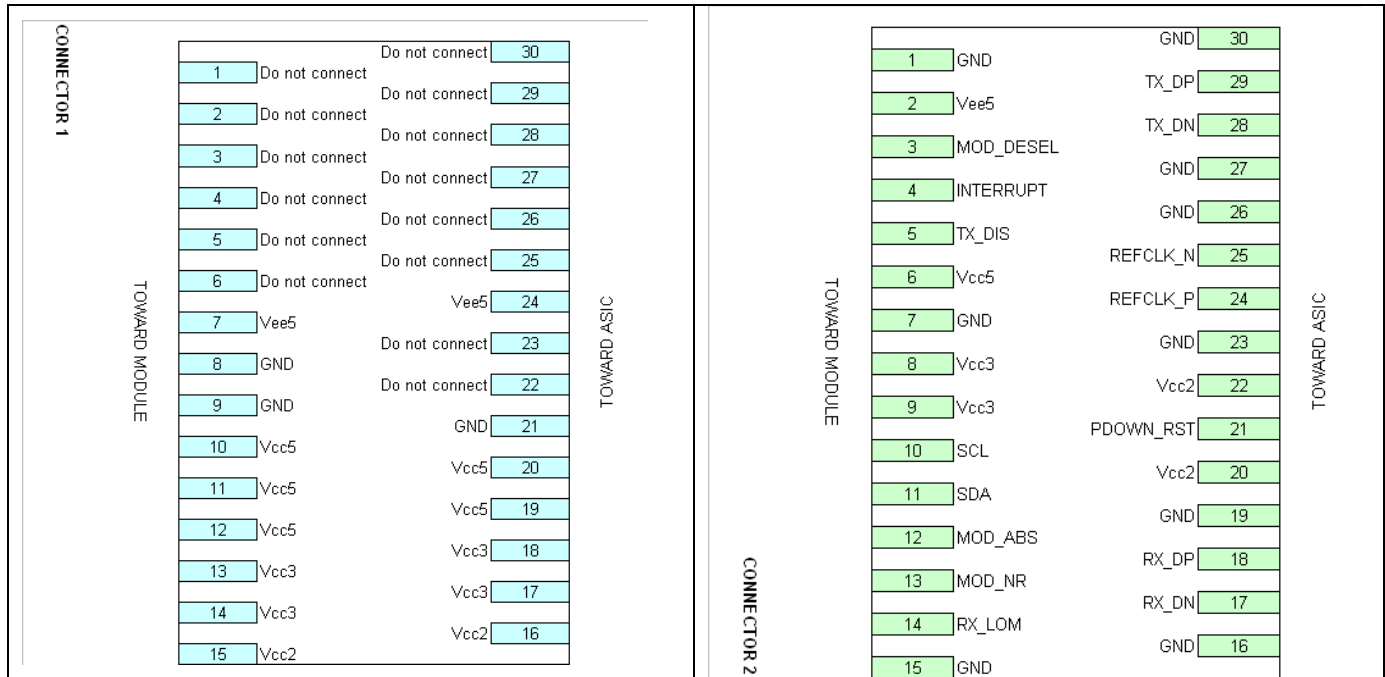

Modular Pin Definitions

Connector 1

Pin	Logic	I/O	Symbol	Name/ Description	Notes
1			DNC	Do Not Connect	
2			DNC	Do Not Connect	
3			DNC	Do Not Connect	
4			DNC	Do Not Connect	
5			DNC	Do Not Connect	
6			DNC	Do Not Connect	
7			VEE5	-5.2V Power Supply	
8			GND	Module Ground	[1]
9			GND	Module Ground	[1]
10			VCC5	+5V Power Supply	
11			VCC5	+5V Power Supply	
12			VCC5	+5V Power Supply	
13			VCC3	+3.3V Power Supply	[2]
14			VCC3	+3.3V Power Supply	[2]
15			VCC2	+1.8V Power Supply	[3]
16			VCC2	+1.8V Power Supply	[3]
17			VCC3	+3.3V Power Supply	[2]
18			VCC3	+3.3V Power Supply	[2]
19			VCC5	+5V Power Supply	
20			VCC5	+5V Power Supply	
21			GND	Module Ground	[1]
22			DNC	Do Not Connect	
23			DNC	Do Not Connect	
24			VEE5	-5.2V Power Supply	
25			DNC	Do Not Connect	
26			DNC	Do Not Connect	
27			DNC	Do Not Connect	
28			DNC	Do Not Connect	
29			DNC	Do Not Connect	
30			DNC	Do Not Connect	

Note:

- [1] Module GND pins are isolated from the module case and chassis ground within the module.
- [2] Shall be pulled up with 4.7k Ω -10k Ω to a voltage between 3.15V and 3.45V on the host board.
- [3] The 1.8V supply can be optionally programmed to voltages lower than 1.8V in modules supporting the variable power supply.

Connector 2

Pin	Logic	Symbol	I/O	Name/ Description	Notes
1		GND		Module Ground	[4]
2		VEE5		-5.2V Power Supply	
3	LV TTL	Mod_DeSel	I	See XFP_Rev4_5_SFF_INF_8077i page 6: Host holds logic LOW to prompt response from TL8000	
4	LV TTL	Interrupt	O	See XFP_Rev4_5_SFF_INF_8077i page 7: active LOW, Host pull-up to VCC. Indicates possible module operational fault or a status critical to the host system	[5]
5	LV TTL	Tx_Dis	I	See XFP_Rev4_5_SFF_INF_8077i page 7: Assert High to disable transmitter output. Pulled High on TL8000	
6		VCC5		+5V Power Supply	
7		GND		Module Ground	[4]
8		VCC3		+3.3V Power Supply	
9		VCC3		+3.3V Power Supply	
10	LV TTL	SCL	BI	2-wire interface clock	[5]
11	LV TTL	SDA	BI	2-wire interface data line	[5]
12		Mod_ABS	O	"Module Absent" – See XFP_Rev4_5_SFF_INF_8077i page 7: Host pull-up to VCC, TL8000 pulls to GND. Indicates module is physically absent if High.	[5]
13	LV TTL	Mod_NR	O	"Module Not Ready" – See XFP_Rev4_5_SFF_INF_8077i page 7: Indicates Module Operational Fault	[5]
14	LV TTL	Rx_LOM	O	Receiver Loss of modulation indicator	[5]
15		GND		Module Ground	[4]
16		GND		Module Ground	[4]
17	CML-O	RxDN	O	Receiver 10G Inverted Data Output	
18	CML-O	RxDP	O	Receiver 10G Non-Inverted Data Output	
19		GND		Module Ground	[4]
20		VCC2		+1.8V Power Supply	[6]
21	LV TTL-I	PDown_RST	I	See XFP_Rev4_5_SFF_INF_8077i page 7: <ul style="list-style-type: none"> Power down; When high, requires the module to limit power consumption to 1.5W or below. 2-Wire serial interface must be functional in the low power mode. Reset; The falling edge initiates a complete reset of the module including the 2-wire serial interface, equivalent to a power cycle. 	
22		VCC2		+1.8V Power Supply	[6]
23		GND		Module Ground	[4]
24	LVPECL-I	CRefP	I	CMU/CDR 1/64 data-rate reference clock	
25	LVPECL-I	CRefN	I	CMU/CDR 1/64 data-rate reference clock	
26		GND		Module Ground	[4]
27		GND		Module Ground	[4]
28	CML-I	TxDN	I	Transmitter 10G Inverted Data Input	
29	CML-I	TxDP	I	Transmitter 10G Non-Inverted Data Input	
30		GND		Module Ground	[4]

Note:

- [4] Module GND pins are isolated from the module case and chassis ground within the module.
[5] Shall be pulled up with 4.7kΩ-10kΩ to a voltage between 3.15V and 3.45V on the host board.
[6] The 1.8V supply can be optionally programmed to voltages lower than 1.8V in modules supporting the variable power supply.

Mechanical Interface

The SX2 module is a pluggable form factor. The following diagram describes the Oclaro mechanical dimensions for integration onto a host card. All dimensions are in mm.

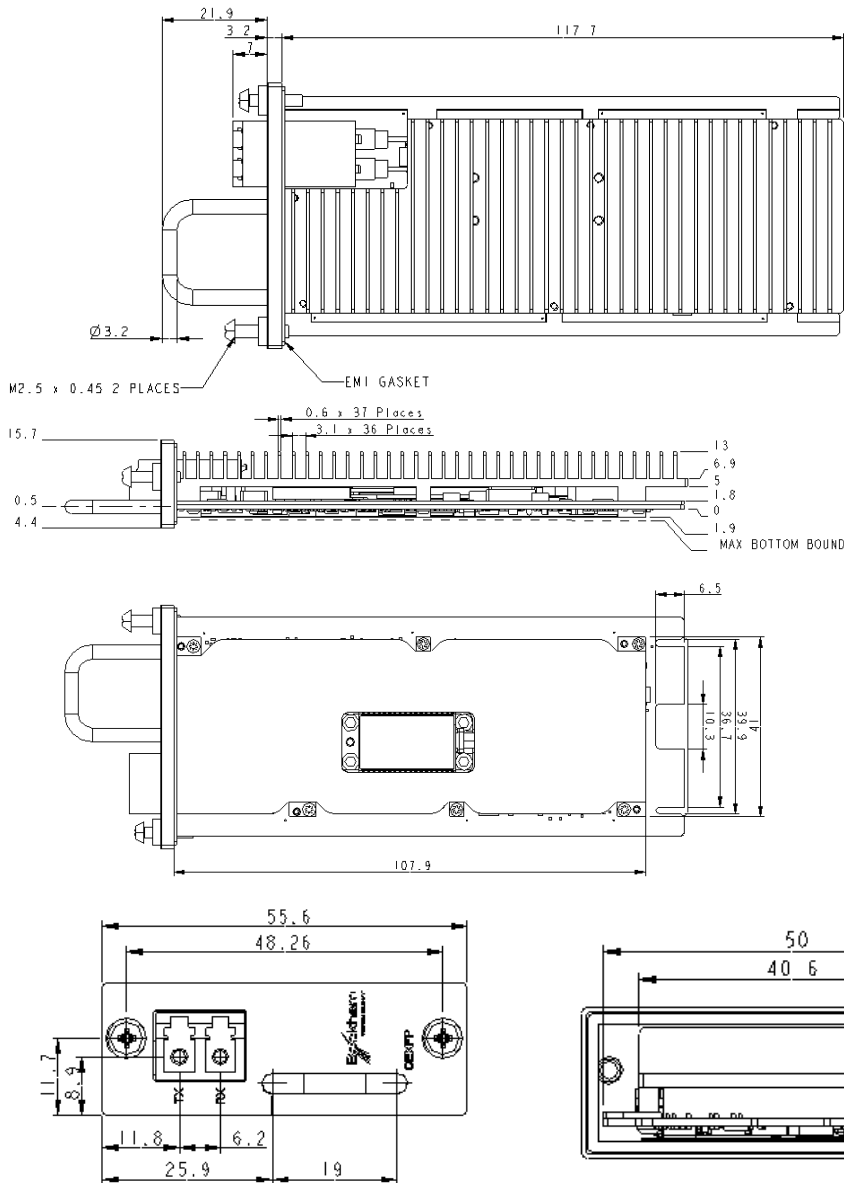

NOTE: The case temperature is measured at the hottest point of the heatsink, indicated above. All specifications are derived using this as the point of reference for case temperature.

Reference Documents

1. XFP MSA revision 4.5, INF-8077i, April 13, 2004
2. SONET GR-253-CORE Issue 3, September 2000
3. IEEE 802.3ae
4. D00364-AN - TL8000 (SX2) Tunable Pluggable Transceiver User Guide for the Evaluation Board
5. D00365-AN - TL8000 (SX2) Tunable Pluggable Transceiver User Guide for the Evaluation Software
6. D00372-AN - TL8000 (SX2) Command and Register Summary Document

Regulatory compliance

Oclaro TL8000 transceiver is designed to be Class 1 Laser compliant. They are certified per the following standards:

Feature	Agency	Standard	Certificate / Comments
Laser Safety	FDA/CDRH	CDRH 21(J) CFR 1040.10 Laser Safety	TBC
	TÜV	IEC/EN 60950-1:2001 IEC/EN 60825-1/A2:2001	TBC
		CAN/CSA-60825-1-03	TBC
Component Safety	UL/CSA	CAN/CSA-C22.2 No. 60950-1-03 UL 60950-1:2003 UL 94 V-0	TBC
ESD	IEC	MIL-STD-883 Method 3015 IEC61000-4-2	TBC
EMI	FCC/89/336/EE [EU Directive]	Part 15 Class B	TBC
		EN55022, EN55024 Class B	TBC

This product meets the requirements of the relevant EMC standards (EN 55022, EN 55024, FCC Part 15). However the EMC performance of the product within the host system may depend on characteristics of the host system over which Oclaro has no control. It may therefore be necessary to ensure that the host system provides adequate grounding & shielding of the product.

RoHS Compliance



Oclaro is fully committed to environment protection and sustainable development and has set in place a comprehensive program for removing polluting and hazardous substances from all of its products. The relevant evidence of RoHS compliance is held as part of our controlled documentation for each of our compliant products. RoHS compliance parts are available to order, please refer to the ordering information section for further details.

Ordering Information:

TL8000NCA 10G SX2 Full-Band Tunable Transceiver Negative Chirp C-Band RoHS 5/6
 TL8000ZCA 10G SX2 Full-Band Tunable Transceiver Zero Chirp C-Band RoHS 5/6

Patents

This product is protected by US patent numbers 5,524,076 (negative chirp), 6,345,135, 6,654,400, 6,654,534, 6,658,035, 6,687,278, 7,145,923, 7,394,838, 7,555,226, 7,680,374 and other patents and applications pending worldwide.

Contact Information

www.oclaro.com

Important Notice

Performance figures, data and any illustrative material provided in this data sheet are typical and must be specifically confirmed in writing by Oclaro before they become applicable to any particular order or contract. In accordance with the Oclaro policy of continuous improvement specifications may change without notice. The publication of information in this data sheet does not imply freedom from patent or other protective rights of Oclaro or others. Further details are available from any Oclaro sales representative.

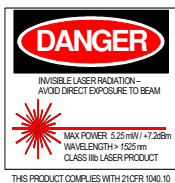

Caution - use of controls or adjustments or performance of procedures other than those specified herein may result in hazardous radiation exposure.

D00223-PB Issue 02 February 2011
 ©Oclaro 2011. Oclaro the Oclaro, Inc. logo, and all other Oclaro, Inc product names and slogans are trademarks or registered trademarks of Oclaro, Inc. in the U.S.A. or other countries. Information in this datasheet is subject to change without notice.